

Technical Note

A CAD CAM digitizing adapter for spinal casts

E. D. LEMAIRE, L. GOUDREAU and Y. JEFFREYS

The Rehabilitation Centre, Ottawa, Ontario, Canada.

Abstract

An adapter was designed to hold a negative cast of a torso in position for mechanical digitization. Once a spinal shape is digitized, the data file can be loaded into a CAD CAM system for modification and manufacturing of a positive model for an orthosis. The adapter currently fits a Seattle Digitizer (M+IND, Seattle, WA); however, the interface unit can be changed to accommodate other commercial digitizers. By using this adapter, current lower limb prosthetic CAD CAM systems can be used to design and manufacture spinal orthoses.

Introduction

Computer Aided Design/Computer Aided Manufacture CAD CAM systems are used in many prosthetic clinics as a manufacturing, research, and/or educational tool (Houston *et al.*, 1992; Krouskop *et al.*, 1989; Lemaire, 1994). While CAD CAM benefits have been shown for prosthetics (Engsberg *et al.*, 1992; Oberg *et al.*, 1993), few orthotic CAD CAM applications have been reported in the literature.

One reason for the lack of orthotic CAD CAM applications could be the difficulty in obtaining the necessary surface topography to produce an orthosis. This is especially true for lower limb orthotics since leg/ankle/foot topography deviates from the conical stump shape encountered in prosthetics. Spinal orthoses, however, have a cylindrical shape which can be accommodated by most prosthetic CAD software packages. Previous literature on CAD CAM and spinal orthosis design involved dedicated spinal cast digitizers to convert a spinal cast shape into a computer data file

(Rashke, 1989; Rashke *et al.*, 1990) or used physical measurements to create mathematically an orthosis shape (Ramos *et al.*, 1994).

Physical measurement based systems required custom software to produce the computerized orthotic shape and, while they are currently used as service tools, do not accommodate severe spinal deformities. The cast digitization approach may require a larger custom digitizer for large models; however, existing prosthetic cast digitizers can be adapted to accommodate the majority of spinal orthotic shapes. Since a positive model can be carved out of medium density foam (IPOS carver¹), orthotic technicians benefit by not having to work with the heavy, plaster spinal cast models during fabrication (foam blanks are approximately 90% lighter than plaster blanks). One contraindication of the foam blanks is that lining materials cannot be stapled on to the foam; therefore, liners cannot be moulded into the orthosis.

To permit spinal cast digitization on a standard prosthetic cast digitizer (Seattle Digitizer, M+IND²), an adapter has been developed to hold a spinal cast in position without requiring special modifications to the cast. This Technical Note describes the design criteria, fabrication procedure, and operation of this device.

Methods

Design criteria

The CAD CAM spinal cast adapter was designed using the following criteria:

- accommodate all spinal cast shapes within the physical limits of the digitizer (58 cm diameter),

All correspondence to be addressed to Edward Lemaire, Institute for Rehabilitation Research and Development, The Rehabilitation Centre, 505 Smyth Road, Ottawa, Ontario, Canada K1H 8M2.

¹IPOS GmbH & Co, KG Zeppelinstraße 30, 21337 Lüneburg, Germany.

²M+IND, 861 Poplar Place South, Seattle, WA 98144, USA.

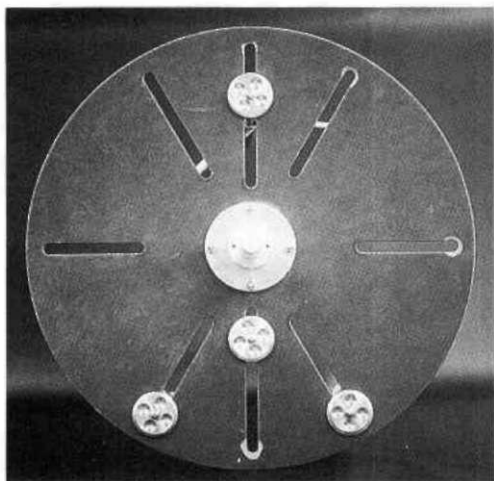

Fig. 1. Inferior view of spinal cast adapter.

- easy cast positioning and digitizer attachment,
- no interference with digitizer operation,
- no cast motion within the adapter frame during digitizing,
- simple device installation and maintenance,
- relatively inexpensive.

Components

The spinal cast adapter has five main components: interface, round table, vertical bars, and attachment arms. The interface section was machined out of aluminium stock to the prosthetic cast holder's dimensions and secured to the bottom of the table with four screws (Fig. 1). Different interface sections could be attached to accommodate different digitizing machines.

Six tracks, 1.3 cm wide were cut in the circular (51.0 cm diameter) table to allow the

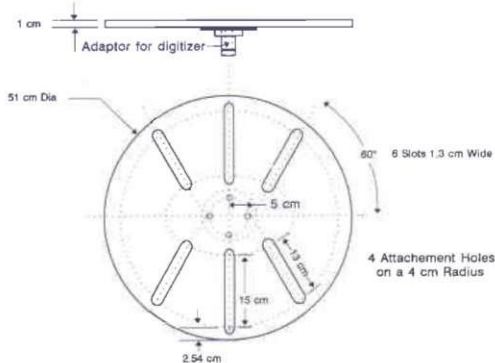

Fig. 2. Base for cast adapter (round table).

vertical bars to move radially from the edge of the table (Fig. 2). Although all six tracks are not needed at the same time, the ability to move the vertical bars to a better angular location could help with extremely asymmetrical shapes. The table dimensions were chosen to provide the largest possible diameter without interfering with digitizer operation.

Four aluminium bars 55.0 cm long by 1.6 cm diameter were used to either support the cast or attach the horizontal bars. The vertical bars were threaded at the bottom so that the threaded end could be inserted through a track and secured underneath by a 5.0 cm threaded disk (Fig. 3).

To prevent axial rotation of the bar within the track, a 1.3 cm by 3.0 cm rectangular key was pinned to the mid-point of the threaded region. A 3.2 cm long, threaded cylindrical piece (threaded sleeve) and a 5.0 cm, unthreaded disk were attached at the top side of the threaded region. After the bar had been placed in the track and the lower disk screwed snugly against the key, the cylindrical piece can be tightened against the table by turning the threaded sleeve (thereby securing the vertical bar's position). This "top tightening/loosening" action allows an orthotist to move the vertical bars to the correct position without having to reach under the table to tighten a nut or screw.

The attachment arms were used to hold the cast in a vertical position. The arms consisted of an aluminium rod 15.0 cm by 1.0 cm diameter

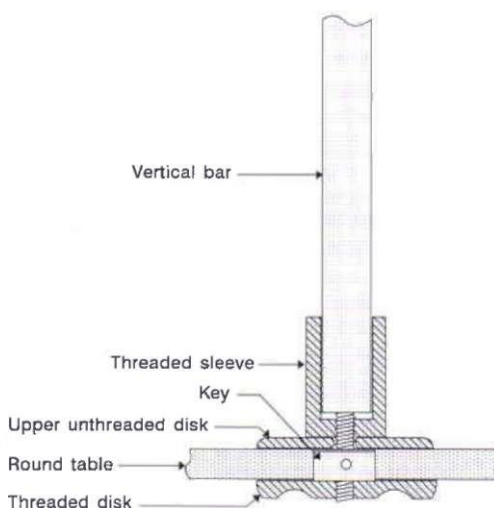

Fig. 3. Vertical bar attachment system.

with a 2.5 by 1.0 cm diameter knurled piece screwed on to the distal end (Fig. 4). This smaller piece was oriented perpendicular to the horizontal bar and was free to rotate about its mid-point to accommodate the cast's contoured surface. An aluminium threaded sleeve was attached to the proximal end of the 15.0 cm rod to secure the attachment arm to the vertical bar.

The locking mechanism is shown in Figure 4. This mechanism simplifies the process of holding the cast in position, moving the attachment arm to the cast's exterior surface, and tightening the arm in position (i.e. hand tightening only, no tools are required to tighten the vertical or horizontal bars). Since the screw section is attached to the bar and the collar, rotating the threaded sleeve will push the locking piece tightly against the horizontal bar.

Installation – operation

Before installing the cast adapter in the digitizer, the orthotist should ensure that the horizontal bars are in the desired tracks and secured to the table. Orthotists at the Rehabilitation Centre have found that having three horizontal bars on the back tracks and one on the centre front track was appropriate for the majority of spinal casts (Fig. 5).

It is important that the cast be aligned correctly when digitizing to facilitate future CAD modifications. Push the centre-back vertical bar forward until it touches the back of the cast and tighten the bar's locking screw. An attachment arm is not required for this vertical bar since the bar acts as a positioning support for the cast. Move the front vertical bar to approximately 5 cm in front of the cast. Two attachment arms are used on this bar to hold the front of the cast. The two attachment arms are rotated to the left and the right of the bar

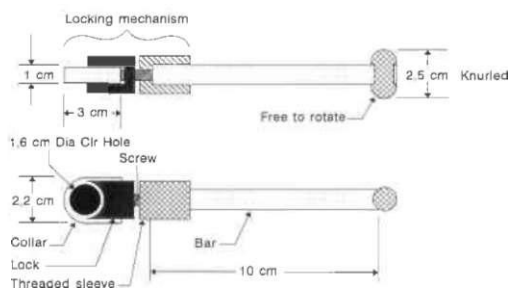

Fig. 4. Horizontal bar design.

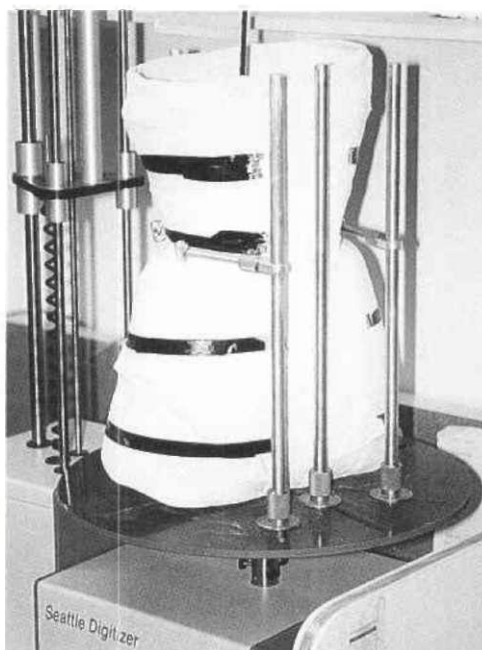

Fig. 5. Spinal cast secured in the digitizing frame.

respectively, pushed tight against the cast, and tightened in place. The remaining two vertical bars are placed 5-8 cm from the sides of the cast. The single attachment arms on these bars are rotated to the side of the cast at a level just above the iliac crests.

During digitizing the clinician or technician may have to slow down the table's angular velocity to ensure that the tracking arm does not skip over high contour areas.

Acknowledgements

The authors wish to acknowledge the technical assistance of Paul Washer and Harold Gay and the administrative assistance of Guy Martel.

REFERENCES

- ENGBERG JR, CLYNCH GS, LEE AG, ALLAN JS, HARDER JA (1992). A CAD CAM method for custom below-knee sockets. *Prosthet Orthot Int* **16**, 183-188.
- HOUSTON VL, BURGESS EM, CHILDRESS DS, LEHNEIS HR, MASON CP, GARBARINI MA, LABLANC KP, BOONE DA, CHAN RB, HARLAN JH, BRNCICK MD (1992). Automated fabrication of mobility aids (AFMA): below-knee CASD CAM testing and evaluation program results. *J Rehabil Res Dev* **29**(4), 78-124.

- KROUSKOP TA, MALINAUSKAS M, WILLIAMS J, BARRY PA, MULLENBURG AL, WINNINGHAM DJ (1989). A computerized method for the design of above-knee prosthetic sockets. *J Prosthet Orthot* 3(1), 131-138.
- OBORG T, LILJA M, JOHANSSON T, KARSZNIA A (1993). Clinical evaluation of trans-tibial prosthesis sockets: a comparison between CAD CAM and conventionally produced sockets. *Prosthet Orthot Int* 17, 164-171.
- RAMOS JV, PELLAS F, VITTON JM, ABELARD P, CONIL JL, DELARQUE A, BARDOT A (1992). Computer aided conception of Cheneau-Toulouse-Munster scoliosis braces: quantitative valuation by comparison with classical craftsman devices. *Clin Rehabil* 6, (suppl), 76.
- RASHKE SU (1989). Applications for Spinal Orthotics. Procedures in: Abstracts; ISPO VI World Congress, Kobe, Japan 12-17 November 1989. ISPO. p268.
- RASHKE SU, BANNON MA, SAUNDERS CG, MCGUINNESS WJ (1990). CAD CAM Applications for Spinal Orthotics - A Preliminary Investigation. *J Prosthet Orthot* 2(2), 115-118.