

Northwestern University Suspension Casting Technique for Hemipelvectomy and Hip Disarticulation

FRED HAMPTON, C.P.¹

INTENDED as an addendum to the article entitled .1 *Hemipelvectomy Prosthesis* which appeared in the Spring 1964 issue of *Artificial Limbs (I)*, this article describes a technique for casting hemipelvectomy or hip-disarticulation "stumps," utilizing a suspension casting

3. Definitive markings can be drawn for relief of bony prominences, scar tissue, etc.
4. Firm wrapping will result in a smooth cast.
5. Positive support is provided for the lateral aspect of the stump.

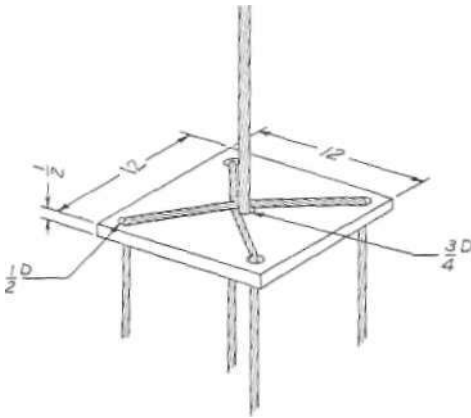

Fig. 1. Spreader constructed from a 12-in. square of 1/2-in. plywood. A 3/4-in. hole is drilled through the center for attachment of the support rope, and a 1/2-in. hole is drilled in each corner for the suspension ropes.

technique. The Northwestern University casting technique differs from others in that the weight is borne over the entire area of the "stump" and lower rib cage rather than just at the distal area.

Advantages to this procedure are:

1. The amputee is supported in a comfortable stance position during the entire casting procedure.
2. Tissues are firmed, allowing an accurate outline of the socket to be drawn on the supporting stockinette.

¹ Assistant Project Director, Northwestern University Prosthetics Research Center, 401 East Ohio St., Chicago, Ill. 60611.



Fig. 2. Inner stockinette held in place by two pieces of 1-in. webbing over the shoulders.

Equipment required includes:

1. Some type of vertical hoist that will permit vertical height adjustment.
2. A spreader strong enough to support the amputee's weight (Fig. 1).



Fig. 3. Two pieces of 6- or 8-in. stockinette used in casting. Suspension sock on left is made of nylon stockinette and has four equidistant points for attachment around the proximal periphery. Because of stresses under weight-bearing conditions, these areas are reinforced by turning down the edge of the stockinette and sewing on a piece of 1-1/2-in. webbing 3 in. in length at the location of each attachment hole.



Fig. 4. Attaching suspension ropes from the spreader to the reinforced holes in the suspension sock.

3. Ropes to suspend the stockinette from the spreader.

The spreader used at the Northwestern University Prosthetics Research Center allows four points of attachment to the stockinette and prevents the ropes from interfering with the amputee's face. It is constructed from a 12-in. square of 1/2-in. plywood. A 3/4-in. hole is drilled through the center for the attachment of the hoist rope, and a 1/2-in. hole is drilled in each corner for the suspension ropes. The suspension ropes are cut long enough to permit each to pass diagonally across the spreader and through the corner holes.

Two pieces of 6- or 8-in. stockinette are required. They must be long enough to cover the body from the level of the nipple line proximally to the level of the upper third of the thigh of the sound leg. The portion that contacts the sound thigh is cut to assure a snug fit and thus provide an anchor point for the stockinette.

The first piece of stockinette is used as a protective covering for the body from the

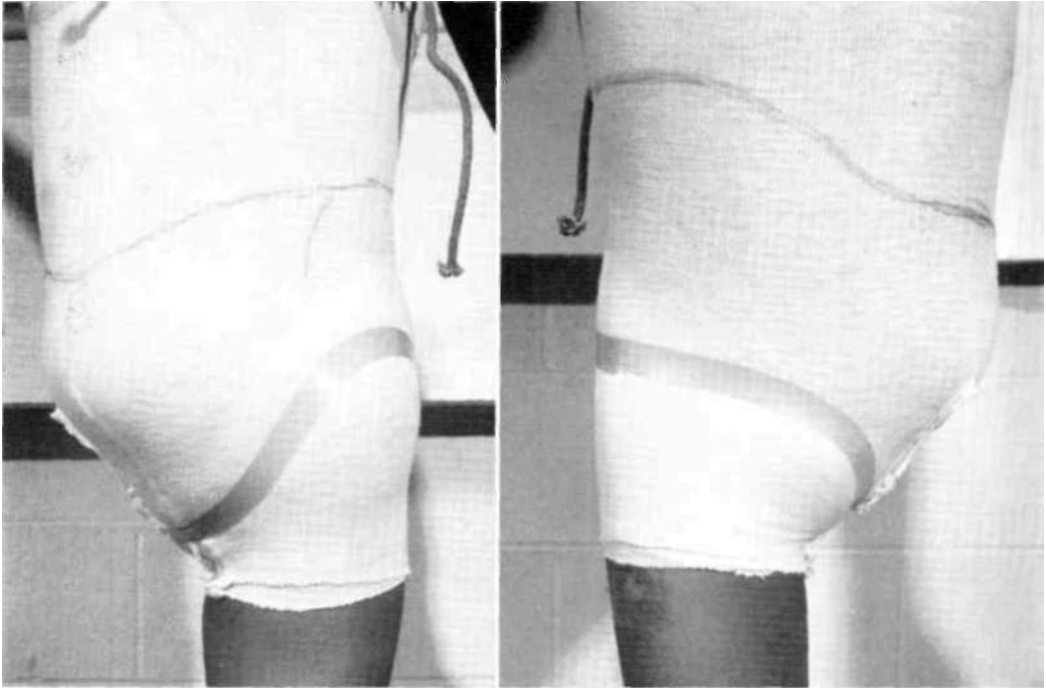

Fig. 5. Starting at the trochanter on the sound side, a strip of pressure-sensitive tape is applied to pass posteriorly over the flare of the gluteal muscles to the sacrum, then distally under the ramus to the anterior aspect of the stump. Anteriorly, the tape is applied across the inguinal crease to the trochanter. In effect, the tape provides the distal outline of the socket.



Fig. 6. Drawing an outline of the socket on the suspension sock to ensure that the plaster wrap will cover the required area.

plaster. It is pulled up over the sound limb and held under firm tension by two pieces of 1-in. webbing over the shoulders (Fig. 2).

The second piece of stockinette is the suspension sock and is made of nylon stockinette. There are four equidistant points of attachment around the proximal periphery. Because high stresses are induced at these points under weight-bearing conditions, these areas must be reinforced. The proximal edge of the stockinette is folded to a depth of 3 in. A piece of 1-1/2-in. webbing 3 in. in length is sewn at the location of each attachment hole. Holes are then cut in the reinforced areas to allow attachment of the suspension ropes (Fig. 3).

The first stockinette is pulled over the amputee and held securely by the shoulder straps. The nylon suspension sock is pulled on and should extend approximately to the nipple line. Before the ropes from the spreader are attached to the suspension sock, the amputee should be standing directly under the line of pull from the hoist. The spreader is lowered until it just clears his head. The suspension



Fig 7. The bilateral hip-disarticulation amputee, who is on a cart, is wheeled into position beneath the suspension bars.

ropes are then attached through reinforced holes (Fig. 4), and the spreader is adjusted until it is in a horizontal position. Tension is applied by means of the hoist until the weight is evenly distributed between the suspension sock and the sound limb. A scale may be used to ensure that the amputee is bearing half of his weight on the sling. The amputee is weighed prior to suspension; then, with the amputee still on the scale, the sling is adjusted by the hoist until half of the amputee's original weight is indicated on the scale.

It is important that the anchor point on the thigh of the sound limb be well fixed. If the suspension sock tends to slip, the distal portion should be anchored with a piece of 1-in. webbing passed under the foot and firmly secured.

Under tension, the suspension sock will have a tendency to bridge in the area of the ramus from the medial aspect of the sound leg to the lateral aspect of the stump. Starting at the

trochanter on the sound side, a strip of pressure-sensitive tape is applied to pass posteriorly over the flare of the gluteal muscles to the sacrum, then distally under the ramus to the anterior aspect of the stump. The genitals are positioned toward the sound side, and the pressure-sensitive tape is applied just superior to these organs and across the inguinal crease to the trochanter. In effect, this is the distal outline of the socket. If applied in the correct manner, the tape produces a good radius in the area of the ramus (Fig. 5).

Under weight-bearing conditions the stockinette will stretch. It is important that sufficient weight is borne by the suspension sock and that adjustments be made if necessary. A general outline of the socket is drawn to ensure that the plaster wrap will cover the required area (Fig. 6). Necessary reliefs are marked, or patches (felt or Kemblo rubber) are glued over areas to be relieved.

The procedure for wrapping the stump is the same as previously described (2, 2).

BILATERAL HIP DISARTICULATION

Various techniques may be employed in casting a bilateral hip-disarticulation amputee; for example, in the prone position with a split cast. To facilitate the procedure for obtaining an intimate Teplica of the stump under weight-bearing conditions, the Northwestern University Prosthetics Research Center has adapted the suspension casting technique.

As in the suspension casting of a unilateral hip-disarticulation amputee, the suspension sock is made from a piece of nylon stockinette. The four points used for attachment of the suspension ropes or webbing must be reinforced by doubling the proximal portion of the nylon sock and sewing a piece of 1-1/2-in. webbing 3 in. in length at each attachment point. Two pieces of 3/4-in. galvanized pipe and a set of parallel bars are used for support of the suspension sock.

Two pieces of stockinette are used in the casting. Both socks must be of sufficient length

to cover the body to the nipple line. The distal portion of each sock is sewn. The first sock is pulled on the amputee, and tension is applied and maintained by means of 1-in. webbing over the shoulders. The suspension sock is pulled up snugly over the amputee. The support bars are fastened to the parallel bars for stability, but it must be possible to slide the posterior support bar. The parallel bars are raised; and the amputee, who is on a cart, is wheeled into position (Fig. 7).

The front attachments of the nylon suspension sock are secured to the front bar, with the amputee lying down. Following this, the amputee is pivoted into an upright position. The back bar is moved forward on the parallel bars until the nylon suspension sock can be secured at the two posterior attachment points (Fig. 8). The cart is removed, allowing the suspension sock to support the weight of the amputee (Fig. 9). Under these weight-bearing conditions, any areas that require relief are marked, and the lower rib cage is outlined (Fig. 10).

Standard plaster bandage is used with firm tension applied during wrapping. The amputee is instructed to hold in his stomach during wrapping, and further flattening is done in this



Fig. 8. The back suspension bar is moved forward on the parallel bars until the suspension sock can be secured at the two posterior attachment points.



Fig. 9. The cart is removed, allowing the suspension sock to support the weight of the amputee.



Fig. 10. Areas that require relief are marked, and the lower rib cage is outlined. The amputee depicted has had some ribs removed. An ileostomy bag was left on during casting, and its position was marked.

area by the hands of the prosthetist (Fig. 11).

When the cast has hardened, the amputee is positioned to ensure that his shoulders are level. Three alignment lines are drawn. By use of a plumb bob, the anterior line is established, originating from the sternal notch. The posterior line originates from the seventh cervical vertebra. A vertical line is established, originating from the axilla, to represent the flexion angle of the socket. The amputee is then released from the support bars onto the cart.

The cast is cut down the anterior surface with a Stryker cast cutter and spread sufficiently to

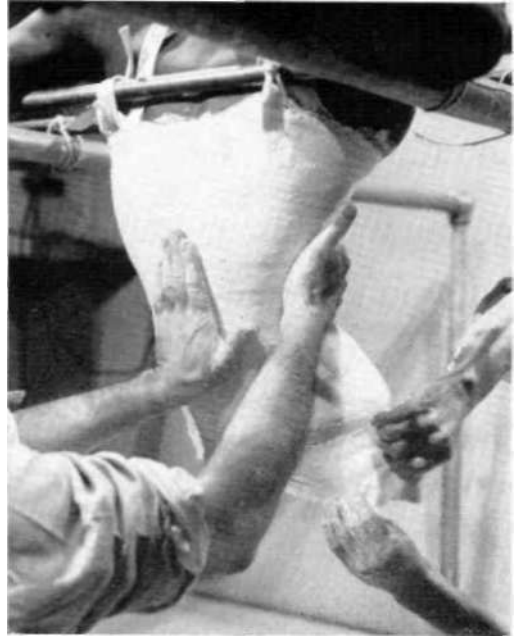

Fig. 11. Flattening the wrap cast in the stomach area.

allow removal from the amputee. After the wrap cast has been closed and a separator has been applied, the cast is oriented in a vertical position by reference to the alignment lines. Plaster for the positive model is poured into the cast, and a holding pipe is inserted in a vertical position. The alignment lines from the wrap cast are cut through to the positive model by use of an awl. These lines are used to locate the positions of the hip joints when the socket is fabricated.

LITERATURE CITED

1. Hampton, Fred, *A hemipellectomy prosthesis*, Artificial Limbs, Spring 1964, pp. 3-27.
2. Hampton, Fred, *A hemipellectomy prosthesis*, Northwestern University Prosthetics Research Center, February 1964.